

EMG 22-LED 7S/ 24

Order No.: 2952305

The illustration shows version EMG 22-LED 7S/ 5

<http://eshop.phoenixcontact.de/phoenix/treeViewClick.do?UID=2952305>Indicator module, with 7 red LEDs and common return line, input
voltage 24 V DC

Commercial data

| | |
|--------------------------|--------------------|
| EAN | 4017918084400 |
| Pack | 10 Pcs. |
| Customs tariff | 85318095 |
| Weight/Piece | 0.05253 KG |
| Catalog page information | Page 564 (IF-2007) |

Product notes

WEEE/RoHS-compliant since:
05/11/2006

<http://www.download.phoenixcontact.com>
Please note that the data given here has been taken from the online catalog. For comprehensive information and data, please refer to the user documentation. The General Terms and Conditions of Use apply to Internet downloads.

Technical data

General data

| | |
|--------------------------------------|--------------|
| Input voltage | 24 V DC |
| Current required per light indicator | Approx. 3 mA |
| Status display | 7 LEDs |
| Width | 22.5 mm |
| Height | 47.5 mm |

| | |
|---|--|
| Length | 75 mm |
| Ambient temperature (operation) | -20 °C ... 45 °C |
| Ambient temperature (storage/transport) | -40 °C ... 60 °C |
| Standards/regulations | IEC 664/IEC 664 A/DIN VDE 0110-1:1989-01, Gr. B for 5, 12, 24, 60 V AC, Gr. C for 250 V AC |
| | DIN VDE 0160 |
| Pollution degree | 2 |
| Surge voltage category | III |
| Mounting position | Any |
| Assembly instructions | In rows with zero spacing |

Connection data

| | |
|--|---------------------|
| Conductor cross section solid min. | 0.2 mm ² |
| Conductor cross section solid max. | 4 mm ² |
| Conductor cross section stranded min. | 0.2 mm ² |
| Conductor cross section stranded max. | 2.5 mm ² |
| Conductor cross section AWG/kcmil min. | 24 |
| Conductor cross section AWG/kcmil max | 12 |
| Stripping length | 8 mm |
| Screw thread | M 3 |
| Type of connection | Screw connection |

Certificates / Approvals

Approval logo



requested approbations

| | |
|---------------|------|
| Certification | GOST |
|---------------|------|

Accessories

| Item | Designation | Description |
|------|-------------|-------------|
|------|-------------|-------------|

Marking

| | | |
|---------|------------|-------------------------------|
| 2947035 | EMG-GKS 12 | Equipment marker, width 12 mm |
|---------|------------|-------------------------------|

Drawings

Circuit diagram

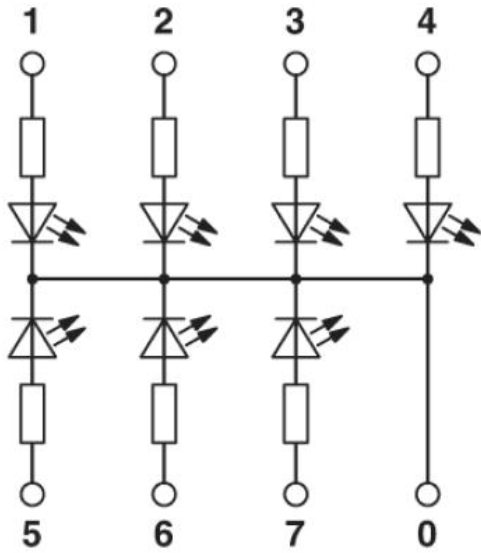

Address

PHOENIX CONTACT Inc., USA
586 Fulling Mill Road
Middletown, PA 17057, USA
Phone (800) 888-7388
Fax (717) 944-1625
<http://www.phoenixcon.com>



© 2008 Phoenix Contact
Technical modifications reserved;